

一般男子 (予選) (1)

(A)

(B)

1R 2R 3R 4R 5R

5R 4R 3R 2R 1R

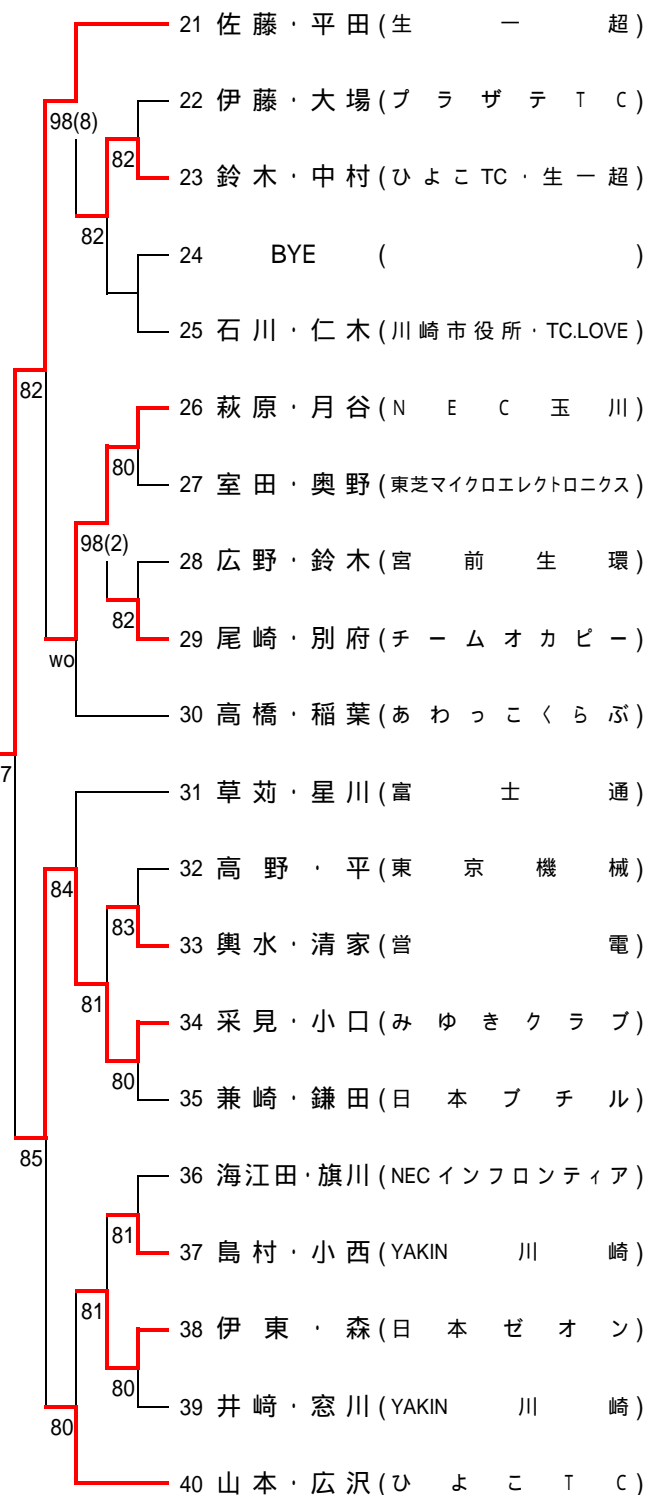

一般男子(予選)(2)

(C)

(D)

1R 2R 3R 4R 5R

5R 4R 3R 2R 1R

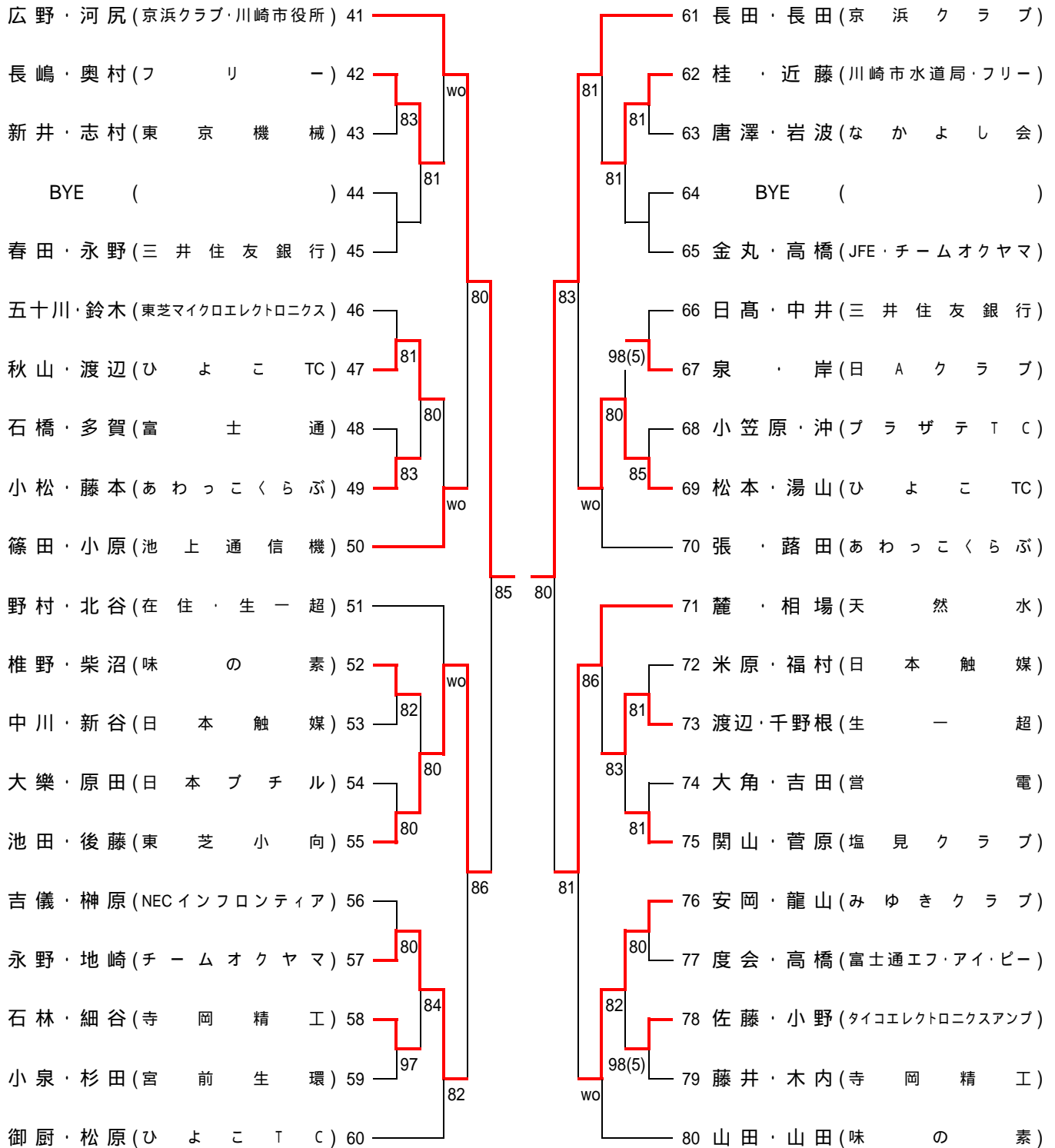

一般男子(予選)(3)

(E)

(F)

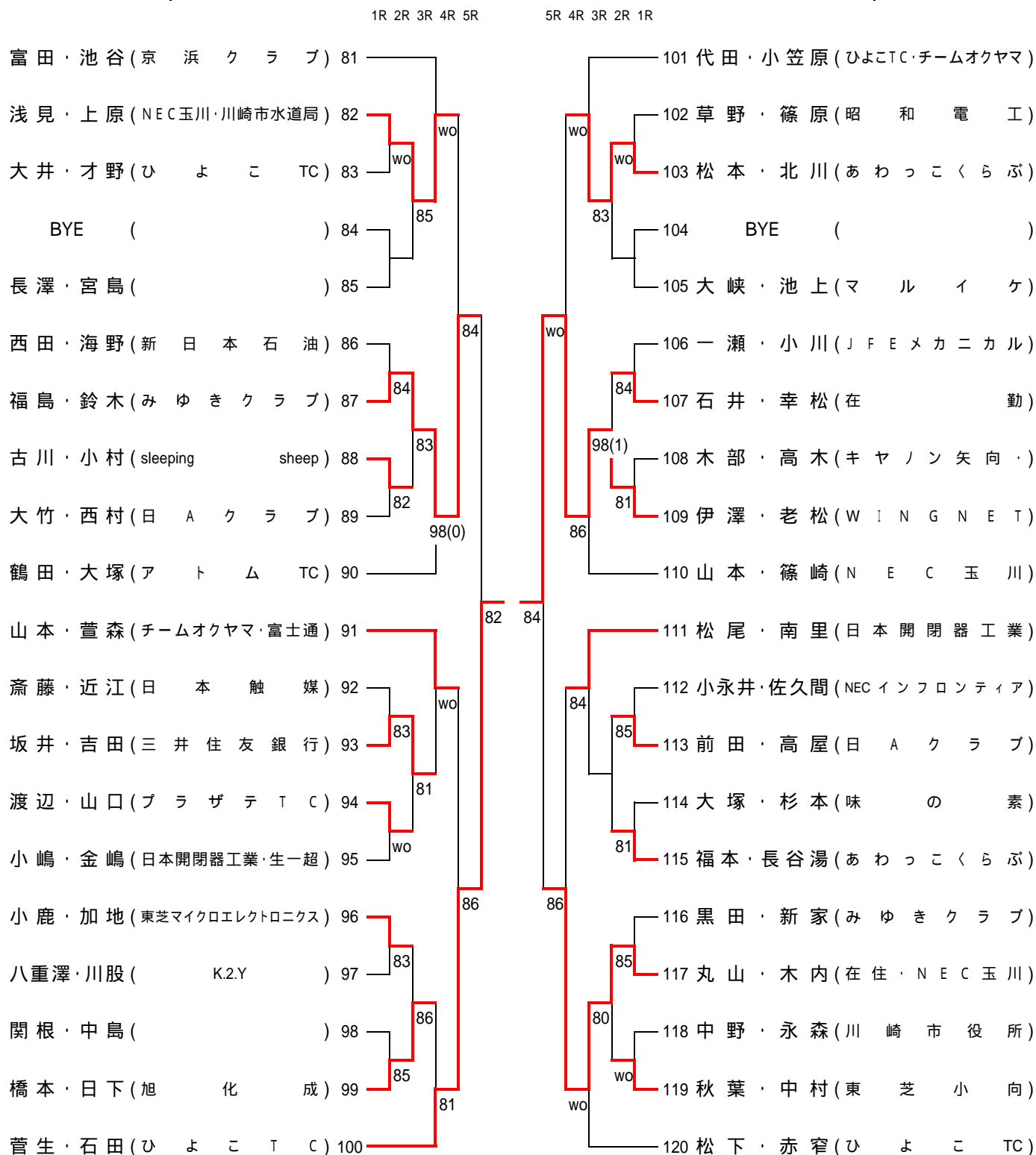

一般男子(予選)(4)

(G)

(H)

1R 2R 3R 4R 5R

5R 4R 3R 2R 1R

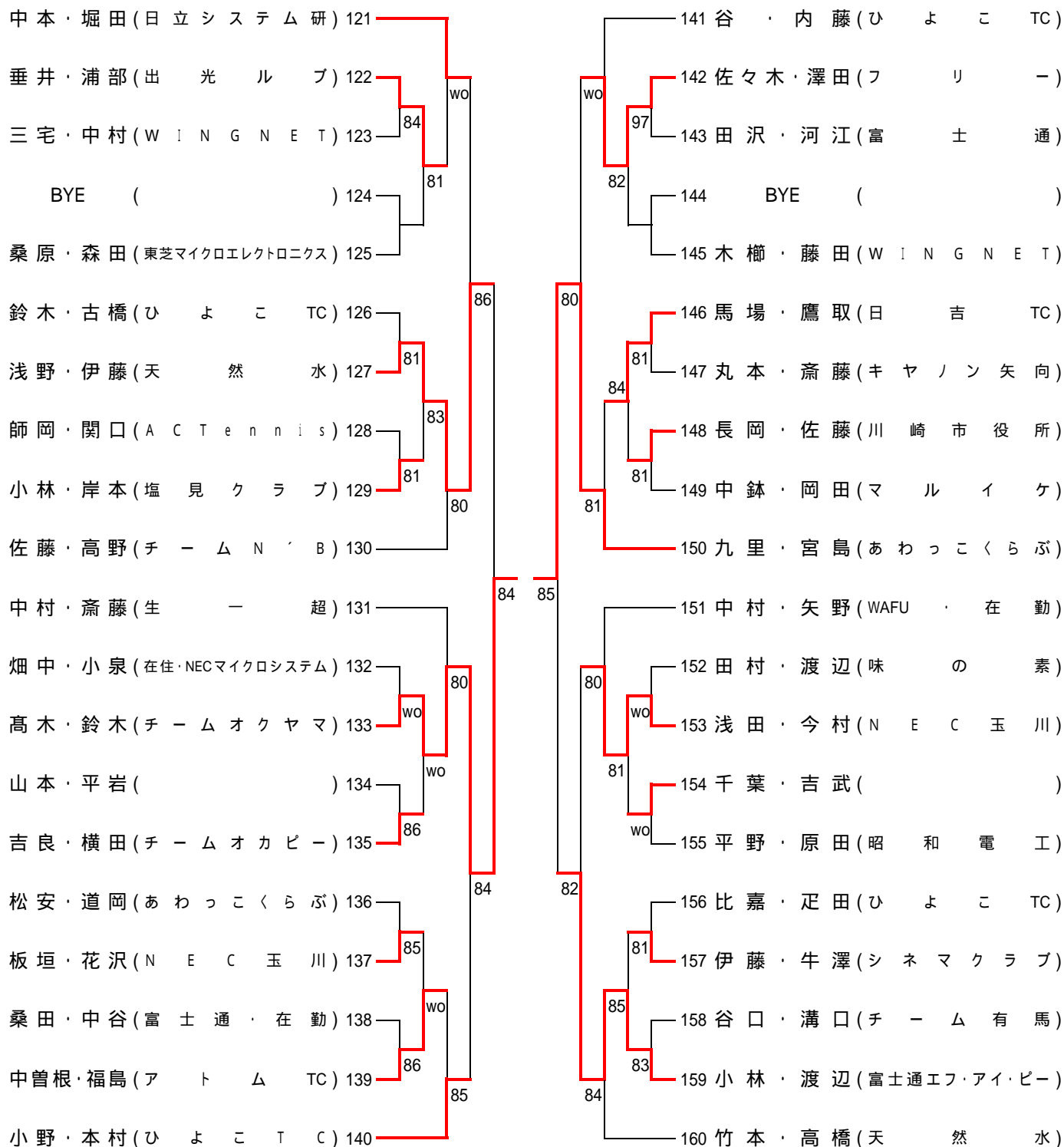

一般男子(予選)(5)

(I)

(J)

1R 2R 3R 4R 5R

5R 4R 3R 2R 1R

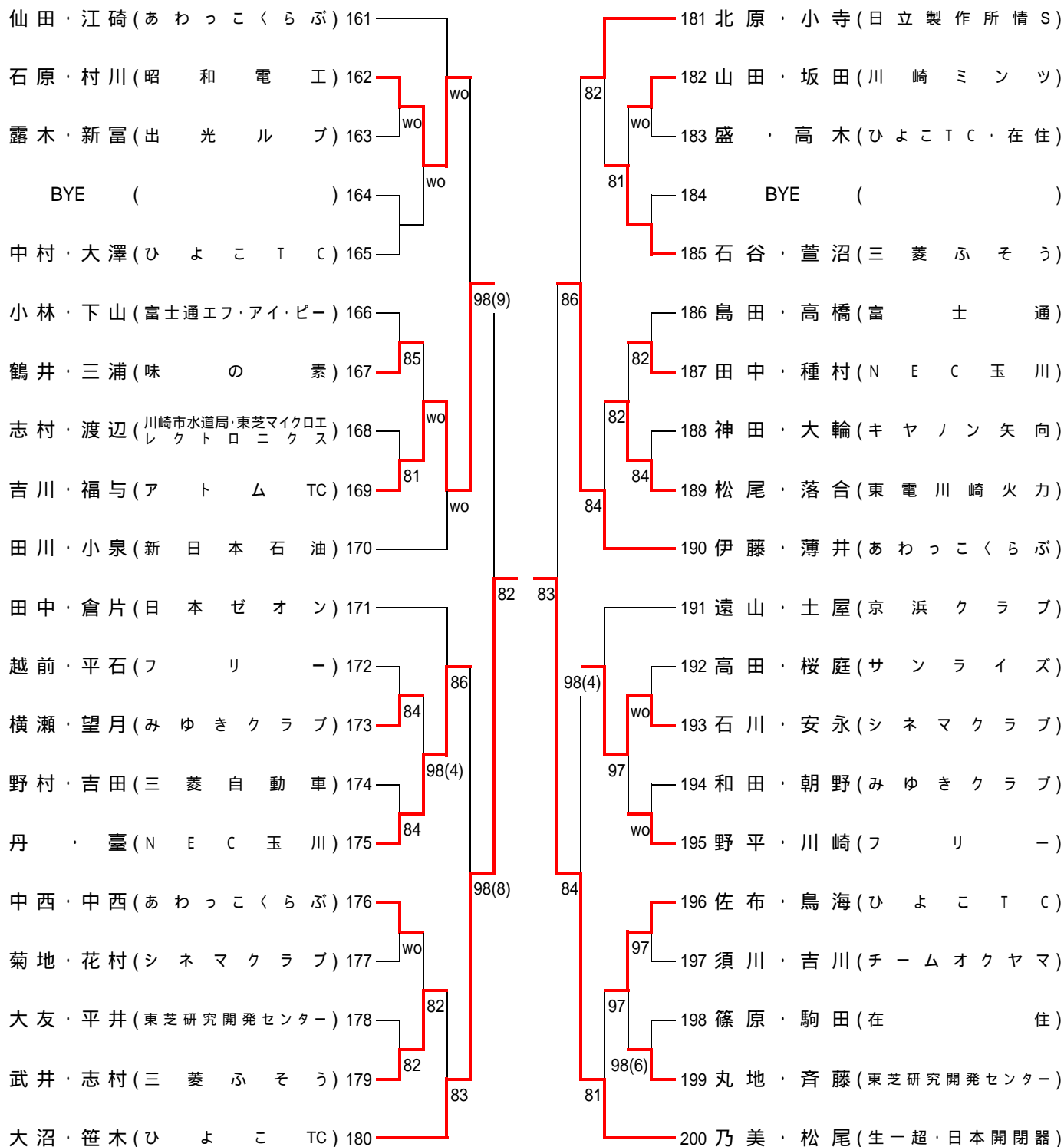

一般男子(予選)(6)

(K)

(L)

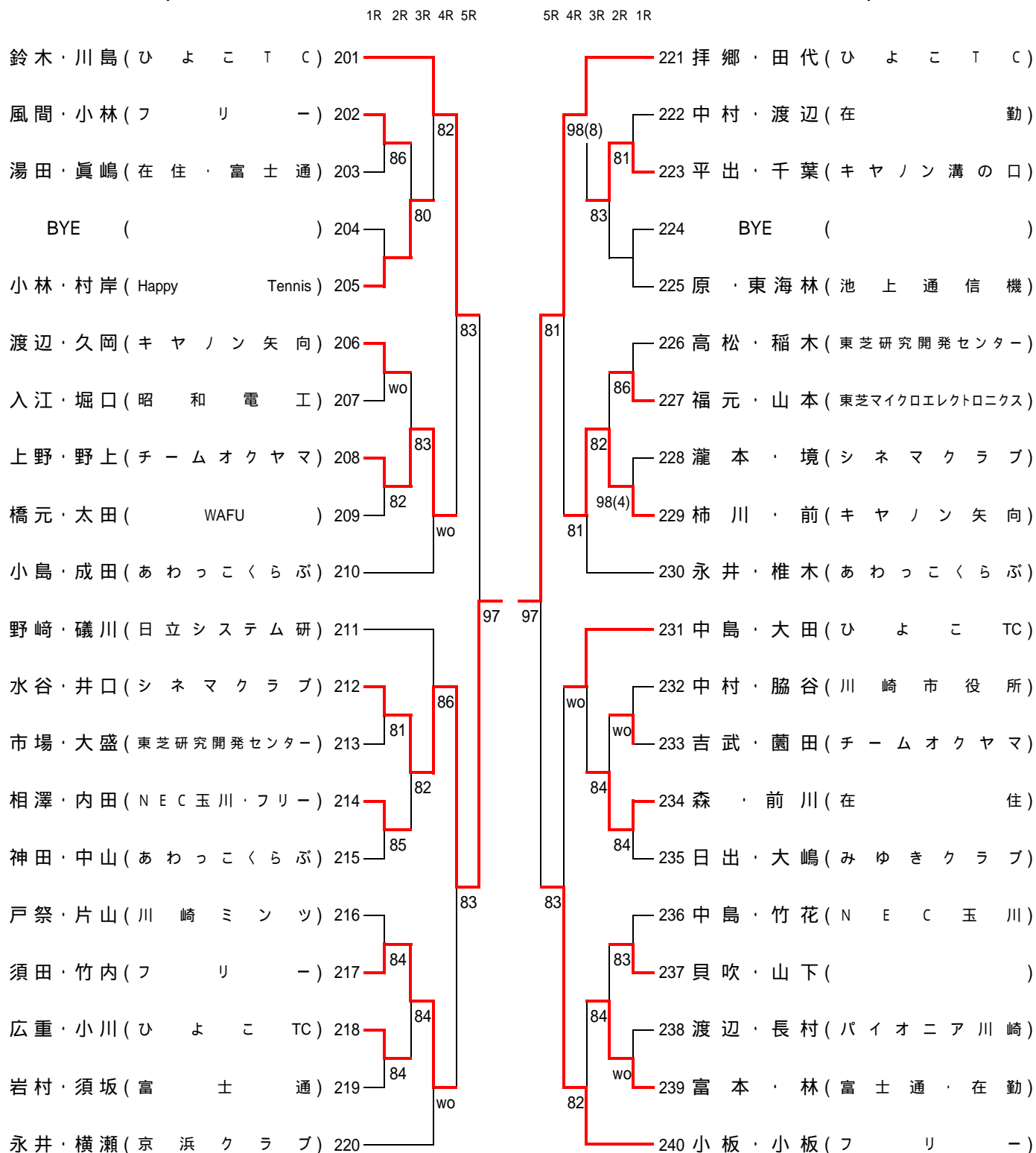

一般男子(予選)(7)

(K)

(L)

1R 2R 3R 4R 5R

5R 4R 3R 2R 1R

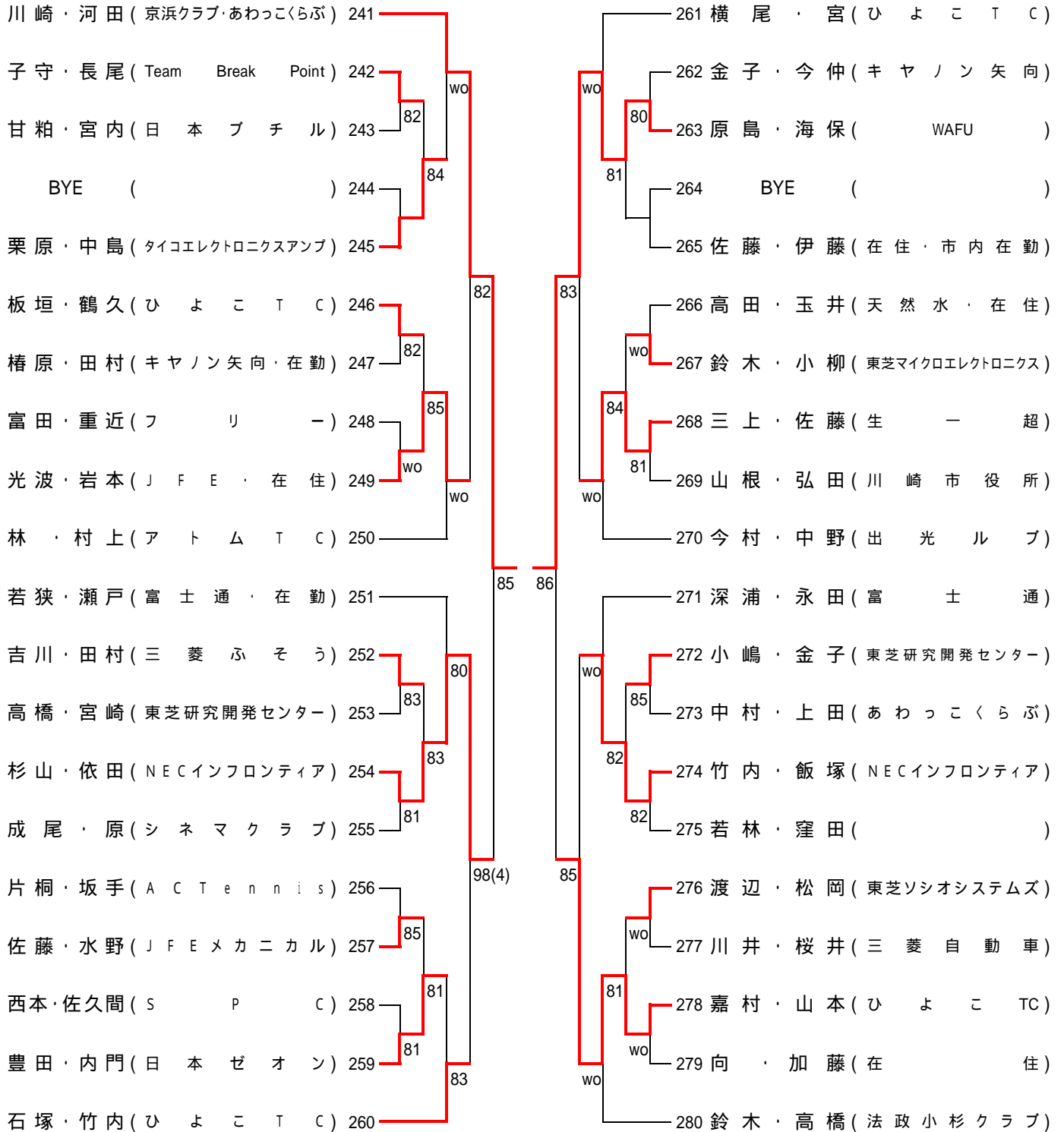

一般男子(予選)(8)

(O)

1R 2R 3R 4R 5R

